

**Land Warfare Studies Centre**

**Working Paper No. 120**

**Information Operations  
during  
Operation *Stabilise*  
in  
East Timor**

by

**Major Kent Beasley**

**August 2002**

© Land Warfare Studies Centre 2002

This work is copyright. Apart from any fair dealing for the purpose of study, research, criticism or review (as permitted under the *Copyright Act 1968*), and with standard source credit included, no part may be reproduced by any process without written permission. Inquiries should be directed to the Head, Land Warfare Studies Centre, Ian Campbell Road, Duntroon ACT 2600.

### **National Library of Australia Cataloguing-In-Publication Entry**

Beasley, Kent, 1965– .

Information operations during Operation Stabilise in East Timor.

ISBN 0 642 29572 7.

1. Information warfare—East Timor. 2. Military intelligence—East Timor. I. Land Warfare Studies Centre (Australia). II. Title. (Series : Working paper (Land Warfare Studies Centre (Australia)) ; no. 120).

355.343095986

### **Land Warfare Studies Centre Working Papers**

ISSN 1441-0389

Working papers produced by the Land Warfare Studies Centre are vehicles for initiating, encouraging or nurturing professional discussion and debate concerning the application of land warfare concepts and capabilities to the security of Australia and its interests. Working papers, by their nature, are not intended to be definitive.

*Series editor: Ara Nalbandian*

### **Disclaimer**

The views expressed are the author's and not necessarily those of the Australian Army or the Department of Defence. The Commonwealth of Australia will not be legally responsible in contract, tort or otherwise for any statement made in this publication.

## About the Author

Major Kent Beasley was an Artillery officer in the Australian Army for 20 years. His final posting in the Army was as Executive Officer, Plans, at the Deployable Joint Force Headquarters in Brisbane. He deployed with the International Force East Timor in September 1999 in Dili, where he was employed on the headquarters as the staff officer responsible for the information operations campaign. He remained with the Deployable Joint Force Headquarters after his return from East Timor as the Information Operations Officer for the 1st Division. He is currently with the Rowland Company in Brisbane, a corporate communication firm, where he is a manager in the issues and crisis management group.

Major Beasley graduated from the Royal Military College, Duntroon, in 1986. He holds a Bachelor of Arts and is currently completing a Masters of Business Administration. He is a graduate of the United Kingdom Gunnery Staff Course (1993).

His previous postings included the 1st Field Regiment; the 4th Field Regiment; the 40th Field Regiment (Royal Artillery); the School of Artillery; and the 6th Battalion, the Royal Australian Regiment.

## Land Warfare Studies Centre

The Australian Army established the LWSC in July 1997 through the amalgamation of several existing staffs and research elements.

The charter of the LWSC is to promote the wider understanding and appreciation of land warfare; provide an institutional focus for applied research into the use of land power by the Australian Army; and raise the level of professional and intellectual debate within the Army. The LWSC fulfils these roles through a range of internal reports and external publications; a program of conferences, seminars and debates; and contributions to a variety of professional, academic and community fora. Additional information on the centre may be found on the Internet at <http://www.defence.gov.au/army/lwsc/>.

Comment on this working paper is welcome and should be forwarded in writing to:

**The Office Manager**  
Land Warfare Studies Centre  
Ian Campbell Road  
DUNTROON ACT 2600  
Australia

Telephone: (02) 6265 9624  
Facsimile: (02) 6265 9888  
Email: [dir.lwsc@defence.gov.au](mailto:dir.lwsc@defence.gov.au)

# CONTENTS

<b>ABBREVIATIONS AND ACRONYMS</b> .....	<b>V</b>
<b>ABSTRACT</b> .....	<b>VI</b>
<b>WHAT ARE INFORMATION OPERATIONS?</b> .....	<b>1</b>
<i>Information Operations Defined</i> .....	2
<i>Information Operations in Overseas Operations</i> .....	4
<i>Recent Australian Campaigns and Information Operations</i> .....	7
<b>STRUCTURE OF THE INTERFET INFORMATION CAMPAIGN</b> .....	<b>9</b>
<i>Information Operations Doctrine</i> .....	9
<i>Information Campaign</i> .....	10
<i>Targeting and Information Operations</i> .....	11
<i>Information Operations Cell</i> .....	11
<i>Plans – Information Operations Relationship</i> .....	14
<i>Strategic Guidance on Information Operations</i> .....	15
<i>Information Operations Staff Planning Tools</i> .....	16
<b>DYNAMICS OF THE INTERFET INFORMATION CAMPAIGN</b> .....	<b>18</b>
<i>Programs, Themes and Messages</i> .....	18
<i>Psychological Operations</i> .....	22
<i>Monthly Reports</i> .....	23
<i>Monitoring of International Media Reporting</i> .....	24
<i>Civil Affairs</i> .....	30
<i>Public Affairs</i> .....	32
<i>Disinformation</i> .....	34
<i>Deception</i> .....	35
<i>Security and Information Operations</i> .....	36
<b>RELATIONS WITH OTHER ORGANISATIONS</b> .....	<b>38</b>
<i>INTERFET’s Relationship with United Nations Agencies and NGOs</i> .....	38
<i>Relationship with Church Groups</i> .....	40
<i>Relationship with UNTAET</i> .....	40
<b>INFORMATION OUTPUTS</b> .....	<b>41</b>
<i>Program and Product Summary</i> .....	41
<i>INTERFET Newspaper</i> .....	43
<i>Radio</i> .....	48
<i>Leaflets</i> .....	52
<i>Loudspeaker Operations</i> .....	57
<b>EFFECTIVENESS OF THE INFORMATION CAMPAIGN</b> .....	<b>57</b>
<i>Measures of Effectiveness</i> .....	57
<i>Key Lessons Learnt</i> .....	60
<b>CONCLUSION</b> .....	<b>62</b>

## ABBREVIATIONS AND ACRONYMS

COMINTERFET	Commander INTERFET
INTERFET	International Force East Timor
IO	Information Operations
JOSCC	Joint Offensive Support Coordination Centre
MAGTF	Marine Air–Ground Task Force
NATO	North Atlantic Treaty Organisation
NGO	Non-government Organisation
psyops	psychological operations
SFOR	stabilization force
UNHCR	United Nations High Commissioner for Refugees
UNTAET	United Nations Transitional Administration East Timor
US	United States

## ABSTRACT

When members of the Australian Defence Force deployed in September 1999 as part of the International Force East Timor (INTERFET), East Timor was an information vacuum. Information networks within East Timor itself were practically non-existent, and the only news service was provided entirely by the international media. This news vacuum presented a unique opportunity for the INTERFET forces and an ideal situation in which the Australian Defence Force could hone its skills in information operations.

This paper aims to capture the lessons learnt in order to refine future information campaigns. It discusses the nature of information operations, but does not seek to theorise about the concepts on which such operations are based; rather it presents a practical view of the conduct of the campaign itself. Information operations are a relatively new concept within the Australian Defence Force and remain shrouded in mystery for many. East Timor proved a valuable testing ground for a concept that has yet to find its doctrinal feet. The INTERFET information campaign was necessarily experimental and opportunistic in nature. While questions still surround the criteria for measuring its effectiveness, the conclusion of this paper is that the information campaign contributed to the success of Operation *Stabilise*.

# **Information Operations during Operation *Stabilise* in East Timor**

## **WHAT ARE INFORMATION OPERATIONS?**

Information operations are aimed at creating a perception in the mind of an adversary or a target audience. In military terms, information operations involve any action taken to manipulate an adversary's image of the friendly forces arrayed against it while defending the friendly forces' ability to capture such information.<sup>1</sup> The use of information is also a powerful tool in disrupting the enemy's decision-making process, particularly through an ability to target information-dependent systems. Information operations also provide an effective means of securing the friendly commander's decision cycle while denying an adversary the ability to achieve situational awareness.

Information operations are usually described as the synchronisation and integration of a number of discrete components. These include psychological operations (psyops), electronic warfare, operations security, military deception, physical destruction, civil affairs, public affairs and counterintelligence. This is not to say that the use of information must comprise all of these components in every situation. It can be adapted or modified in any way to meet the specific conditions of the battlespace. Operational information can be employed at any level of warfare

---

<sup>1</sup> Based on the US Army definition of Information Operations, as it appears in US Department of Defense *Directive-Supplement 3600.1*, December 1996, cited in Major A. Tulak and Major J. Hutton, 'Information System Components of Information Operations', in *Military Review*, vol. LXXVIII, no. 5, September–November 1998, p. 18.

(strategic, operational and tactical) and at any phase of the continuum of conflict (including pre-conflict and post-conflict peace operations).

Information operations are generally divided into three types: offensive, defensive and support. The offensive aspect concentrates on influencing the decision cycle of the adversary's command system so as to 'reduce his warfighting effectiveness, ideally to such an extent that he is forced to capitulate'.<sup>2</sup> The defensive aspect seeks to protect the friendly commander's decision cycle from attack. Supporting information encompasses those activities required for both the attack and defence.

The INTERFET information campaign falls into the broad classification of support information operations. Its dual aim was to shape the psychological perceptions of large elements of the population and to mould opinion where possible. In Operation *Stabilise* the campaign was not aimed at attacking the computer networks of an enemy or waging electronic warfare against an opponent. Rather, the campaign aimed to defend the reputation of the peacekeeper and to protect the local population—particularly displaced persons—from the fear caused by disinformation. The campaign was geared to the role and charter of the peacekeeper, with the ultimate aim of securing the local population.

### **Information Operations Defined**

INTERFET's use of information operations was dictated by circumstances rather than by the Australian Defence Force

---

<sup>2</sup> R. J. Staker, *An Application of Checkland's Soft Systems Methodology to the Development of a Military Information Operations Capability for the Australian Defence Force*, Defence Science and Technology Organisation, Department of Defence, Salisbury, SA, 1999, p. iii.



definition of information operations, which is aimed fairly and squarely at decision superiority. According to this definition, information operations are ‘the systematic coordination of a range of information related activities to produce a planned or tailored effect on the decision making of an adversary and to protect our own decision superiority’.<sup>3</sup> Information is vital in gaining and maintaining decision superiority. It is ‘a key Australian Defence Force warfighting concept and a force multiplier, offsetting comparative disadvantages in force size or equivalence in weapons technologies’.<sup>4</sup> The vital role of information operations in a relatively small army is thus assured.

Similarly, Canadian doctrine argues that the principal objective of information operations is to achieve information superiority, which is defined as ‘the disparity between what friendly forces know about their Area of Operations and operations within it and what the enemy knows’.<sup>5</sup> The United States (US) Marine Corps doctrine regards information operations as a central nexus for force enhancement: ‘information operations enhance the ability of the MAGTF [Marine Air–Ground Task Force] to project power during peace and war, complementing and facilitating the traditional use of military force’.<sup>6</sup> Clearly, information is a powerful tool in shaping the battlespace. As the various

---

<sup>3</sup> ‘The Knowledge Edge and Information Operations: A Plain English Version’, C4ISREW Staff, Defence Headquarters, Canberra, February 2000, cited in V. Sobolewski, ‘Information Operations: Cornerstone of an RMA?’, in *Australian Defence Force Journal*, no. 146, January–February 2001, p. 30.

<sup>4</sup> *Ibid.*

<sup>5</sup> Canadian Armed Forces, *Land Force Information Operations*, National Defense, Canada, Kingston, Ont., January 1999, p. 3.

<sup>6</sup> Marine Corps Warfighting Publication 3-40.4, ‘Information Operations’ (draft), Department of the Navy, Headquarters United States Marine Corps, Washington DC, December 2001, p. 3.

definitions suggest, information has the potential to allow the friendly commander to enter the mind of his adversary in order to influence his perceptions and disrupt his decision cycle. Information can provide vital protection or denial of access to friendly information, and it can win or lose the hearts and minds of an entire nation.

### **Information Operations in Overseas Operations**

Given its potential to act as a ‘force enhancer’, ‘force multiplier’ and the means of achieving decision superiority, it is not surprising that information operations have played a major role in a number of international operations. The versatility of information in the hands of both friendly and adversary forces is ably demonstrated by the US Army and US Air Force during operations in the former Yugoslavia.

The US SFOR (Stabilization Force) peace operations in Bosnia–Herzegovina involved a concerted information campaign designed to win acceptance of the Dayton Peace Accord. While SFOR did not face an ‘enemy’ as such, the former warring factions and local populace were often hostile to both the US forces and the Dayton Peace Accord itself. The SFOR information campaign was aimed at undermining the legitimacy of the leadership of the former warring factions when they threatened the implementation of the Dayton Peace Accord. The decision-making process and command and control were the primary targets, enabling SFOR to potentially ‘control the adversary’s decision-process tempo and even cause it to collapse’.<sup>7</sup> The information campaign targeted the popular support base of the local leadership, thus undermining its credibility and legitimacy. In addition, the campaign aimed to persuade the

---

<sup>7</sup> Major General D. Grange and Colonel J. Kelley, ‘Information Operations for the Ground Commander’, cited in Tulak and Hutton, *op. cit.*, p. 25.

populace to support the Dayton Peace Accord and SFOR objectives.<sup>8</sup> The US verdict on the use of information operations in Bosnia–Herzegovina was overwhelmingly positive. Information operations were in fact labelled ‘the most effective nonlethal element the division could employ’.<sup>9</sup>

The US experience during the air war against Serbia, the 78-day Operation *Allied Force* in 1999, demonstrated the effectiveness of an adversary information campaign in the failure of the United States to win the ‘media war’ at the time. As one US Air Force officer observed:

Allied Force [will] be remembered for the first true ‘media war’, in which the power of instantaneous coverage and dramatic visual images rendered strategic importance to a handful of tactical events and threatened to undermine political and military coalitions in the process. The power of public information—particularly television images—to influence and transform public opinion cannot be underestimated, even in an air war that lasted just 78 days.<sup>10</sup>

While the United States and its North Atlantic Treaty Organisation (NATO) allies prepared a comprehensive information campaign designed to flood the airways with positive ‘spin’ long before the first bombs fell, the Serbs also conducted their own information campaign. They proved themselves masters of the media in a campaign that many believe the NATO forces were powerless to match.

---

<sup>8</sup> Lieutenant Colonel D. Murphy, ‘Information Operations in the Nontraditional Battlefield’, cited in Tulak and Hutton, *ibid.*

<sup>9</sup> Tulak and Hutton, *ibid.*

<sup>10</sup> Major G. Pounder, US Air Force, ‘Opportunity Lost: Public Affairs, Information Operations, and the Air War Against Serbia’, in *Aerospace Power Journal*, vol. 14, no. 2, Summer 2000, p. 57.

Admiral James Ellis, Commander of the Allied Forces in southern Europe during Operation *Allied Force*, observed:

the enemy was much better at this [public information and public affairs] than we were and far more nimble. The enemy deliberately and criminally killed innocents by the thousands, but no one saw it . . . We accidentally killed innocents, sometimes by the dozens, and the world watched on the evening news. We were continuously reacting, investigating, and trying to answer, ‘how could this happen?’.<sup>11</sup>

The media appeared to exercise a disproportionate influence in shaping and reshaping the terms of the conflict at will. Dr Jamie Shea, NATO’s chief spokesman observed that the result of media obsession with NATO collateral-damage incidents was that the ‘0.1 per cent of failure’ was translated as ‘the central drama of the conflict and the yardstick for judging NATO’s military and moral effectiveness’.<sup>12</sup> The NATO media efforts comprised a range of initiatives both within and outside the information campaign. These efforts included the construction of a web site that incorporated responses to media questions on the nature of forces employed in Kosovo. Despite stringent opposition from intelligence quarters, the site remained open since, interestingly enough, it appeared to have a deterrent effect, as evidenced by the numerous recorded hits from Serb Internet sites, including government organisations.

---

<sup>11</sup> Admiral J. Ellis, briefing entitled, ‘A View From the Top’, cited in Pounder, *ibid.*

<sup>12</sup> J. Shea, ‘The Kosovo Crisis and the Media: Reflections of a NATO Spokesman’, speech before the Atlantic Council of the United Kingdom, Reform Club, London, 1999, cited in Pounder, *ibid.*, p. 58.

Other initiatives included the flooding of the broadcast space with news, and creating a 24-hour update facility that ensured that no television watcher was left bereft of the NATO message. What was lacking, however, was the development of any level of expertise on the adversary, particularly during the initial stages of the campaign. This lack of expertise proved to be the Achilles heel of the information operations campaign, crippling its ability to respond to Serb propaganda effectively. As Jamie Shea indicates, ‘If we had had this expertise from the beginning, we could have anticipated some of Milosevic’s moves and learned to counter them better’.<sup>13</sup>

### **Recent Australian Campaigns and Information Operations**

In the post–Cold War era, Australian forces have recognised the crucial nature of information operations in overseas deployments. Operations such as *Solace* (Somalia, 1992–94), as well as deployments to Rwanda (1994–95) and Bougainville (1997 on) were characterised by the necessity to collect culturally specific information on the local populace in order to construct information campaigns. In 1997, Operation *Bel Isi* saw Australians deployed as part of the Truce Monitoring Group (later the Peace Monitoring Group) to the island of Bougainville. A range of intelligence elements was utilised in what was a relatively sophisticated information campaign, applied in practical form by the Military Information Support Team.

The primary purpose of the team was to create an environment of positive public perception that would allow the smooth operation of the Monitoring Group. The performance of the Military Information Support Team was particularly effective in creating the necessary environment

---

<sup>13</sup> *Ibid.*, p. 70.

for the Combined Military Information Office to operate efficiently. The primary task of the office was ‘to seek specific information relevant to the commander’s requirements, grade it and report it for analysis in conjunction with other information’.<sup>14</sup>

The Military Information Support Team itself was also responsible for a range of information operations products, including a magazine and newspaper. By mid-1998 the team had distributed a total of 506 050 products of all types.<sup>15</sup> The significance of the information operations in this campaign was evidenced in the strength of the relationship between the Monitoring Group and the local community. While operations such as *Bel Isi* provided the opportunity for the conduct of some aspects of information operations, it was the deployment of INTERFET in September 1999 that afforded the Australian Defence Force its first real opportunity to conduct information operations as the lead nation of a large multinational force in peace support operations. Prior to Operation *Stabilise*, the Australian Defence Force had not implemented an information operation in its entirety.

---

<sup>14</sup> Major P. Clark, ‘The Road to Peace: Aspects of Information Operations Applied to Peace Monitoring Operations on Operation BEL ISI, Bougainville 1997–98’, in *Combat Arms*, Issue 2/98, Combined Arms Training and Development Centre, Puckapunyal, Vic., 1999, p. 68.

<sup>15</sup> Clark, *ibid.*

## STRUCTURE OF THE INTERFET INFORMATION CAMPAIGN

### Information Operations Doctrine

Australian Defence Force information operations doctrine is very much in its infancy.<sup>16</sup> Similarly, US Army information operations doctrine, *FM 100-6*, dates from 1996 and has been refined during US peace enforcement operations in Bosnia and Kosovo. *FM 100-6* is now supplemented by the joint publication, *FM 3-13*, produced in 1998. Like the US experience in the former Yugoslavia, the lessons learnt on Operation *Stabilise* will afford the Australian Defence Force an excellent platform to support the drafting of much-needed doctrine on information operations.

It should be noted, however, that both the US and Australian experiences reinforce the fact that, while doctrine provides the underpinning principles, an information campaign itself must be adapted to the specific local environment. Such an environment includes elements such as the level of conflict, the nature of operations, the terrain, the adversary and the level of resources allocated. The specific environment will dictate the mix of information operations components and the structure of the campaign itself.

The INTERFET information campaign was centred on a triumvirate of psyops, public affairs and civil–military operations, with civil affairs as a secondary element. The role of civil affairs was primarily to build a relationship between the INTERFET forces and the local community. The broader objectives of civil–military operations

---

<sup>16</sup> The Australian Defence Force Warfare Centre's 'IO Staff Planning Manual' is the only official reference on Information Operations and is still at the interim stage.

embraced a range of activities ‘designed to enhance military effectiveness, support national objectives and reduce the negative aspects of military operations on civilians’.<sup>17</sup> This definition also includes measures aimed at protecting and controlling the population, and offering humanitarian and other forms of assistance to the host region.

### **Information Campaign**

The Australian Defence Force information campaign in East Timor attempted to ensure that Australian forces utilised all available INTERFET assets to achieve information dominance in the area of interest. Its purpose was also to shape the information environment in such a way that it contributed to the success of the operation. INTERFET personnel and agencies utilised all available means to conduct information operations. While this necessarily took the form of a coordinated and synergistic effort, it also had to remain cognisant of national command objectives. The overall objective of the information campaign lay in its making a significant contribution to the success of the INTERFET mission, and its ability to support a state of enduring peace and security in East Timor. With this as the central aim, INTERFET developed and prioritised information operations programs, themes and messages, and distributed them to selected target audiences throughout East Timor.

The friendly centre of gravity was identified as being the actual credibility of INTERFET’s information campaign. If at any stage the militia groups, the media or third parties had discredited the information campaign, it would have been unlikely to succeed. The process of identifying the centre of gravity, critical elements and critical vulnerabilities proved

---

<sup>17</sup> *ADFP 44, Civil–Military Cooperation*, Australian Defence Force Warfare Centre, November 1998, p. 7-1.



to be the key to maintaining the integrity and credibility of the campaign.

### **Targeting and Information Operations**

The information campaign had to be planned and executed in accordance with the principles of targeting, thus reinforcing its position as an element of conventional military operations. This fusion of information operations and targeting appeared to be seamless, because the principles of targeting have traditionally included the use of information as a response asset. As the experience of at least one other information campaign indicated:

The targeting process in peace operations is essentially the same as that employed in high intensity operations. It is a logical process that decides what must be attacked, how and when it will be engaged, and then matches the best attack asset to the target.<sup>18</sup>

The application of information operations along the principles of targeting effectively increases the weaponry available to the commander in terms of both offensive and defensive assets for use at any stage of conflict.

### **Information Operations Cell**

Ownership of information operations within the Australian Defence Force is the subject of some debate. The responsibility for information operations during INTERFET resided with the Offensive Support Current Operations Officer from the Joint Offensive Support Coordination Centre (JOSCC). Although information operations were not previously considered a function of the JOSCC, the nature of offensive support planning and the procedures used for

---

<sup>18</sup> B. Alsop, 'What are Information Operations? Why Should I Take Any Notice?', *Australian Defence Force Journal*, no. 140, January–February 2000, p. 33.

synchronising assets meant that information quickly assumed some significance within the JOSCC itself. In the past, the JOSCC had always worked closely with the combined operations and combined intelligence branches. While the JOSCC boasted no technical expertise in any one of the information operational functions, including psyops, public affairs or civil–military operations, it retained the ability to ensure that individual capabilities were synchronised to maximise their collective output. The Information Operations Cell did not own any assets but was purely a coordinating and synchronising cell that focused on effects. However, the critical issue on the conduct of information operations during Operation *Stabilise* concerned the functionality of the JOSCC itself. The lingering question remained that of whether or not the JOSCC could conduct information operations along with its traditional offensive support function during conventional operations.

Under the US model of information operations, the senior officer was usually a lieutenant colonel. Under the Australian model of information operations employed during INTERFET, the senior officer was a major. While this difference in rank did not present any problem in terms of the performance of the staff function—that is, developing the plan, synchronising assets and executing the plan—it would have been more appropriate for a lieutenant colonel to have directed the activities of the Information Operations Cell. In East Timor such an arrangement would have placed the Information Operations Officer at the same rank as the other principal staff officers on the headquarters, in particular the commanding officer of the Combined Public Information Centre. The US experience in Bosnia was that ‘the [Combined Public Information Centre] Director and IO Cell Chief formed a powerful team that resulted in tighter synchronisation of IO throughout the Division, and in more

effective themes and messages'.<sup>19</sup> Within INTERFET, the Combined Public Information Centre and the Information Operations Cell were often at odds with each other over priorities and the employment of assets due to different and sometimes competing objectives.

By far the most significant staffing issue for the Information Operations Cell concerned priority of effort. Given the lack of available personnel, the Information Operations Cell found its very existence dependent on the residual staff effort of the intelligence and public affairs organisations. This situation proved to be less than ideal, and while significant contributions were made, at times it was difficult for the cell to function as a team with information operations as its primary focus. The public affairs planning function, for example, was performed by a captain from the Combined Public Information Centre who devoted a portion of her time to information operations. The importance of staffing levels in maintaining an effective Information Operations Cell is a constant theme in reports from information campaigns in other theatres. The public affairs areas, in particular, often suffered the consequences of limited staffing: 'limited manning was truly killing us. Our staff routinely worked 15- and 16-hour days, seven days a week'.<sup>20</sup> One officer serving in a public affairs appointment during Operation *Allied Force* recalls that he 'once literally began dozing in the middle of a live interview on BBC radio, after a series of marathon workdays'.<sup>21</sup>

Under INTERFET, an Information Operations Working Group was formed to assist in the information-planning

---

<sup>19</sup> *Ibid.*

<sup>20</sup> Captain J. Haynes, Public Affairs, US 31st Fighter Wing, cited in Pounder, *op. cit.*, p. 70.

<sup>21</sup> Pounder, *ibid.*

cycle. At this stage the Information Operations Cell was still operating in something akin to a doctrinal vacuum. Draft Australian Defence Force doctrine provided some overarching guidance, but the tactics, techniques and procedures that would normally be found in endorsed doctrine or standing operating procedures did not exist.

The appointment of an operations lieutenant colonel to oversee information operations was sound in theory, since the use of information crossed many staff functions, particularly intelligence and operations. In practice, however, it proved difficult. The Information Operations Officer and operations staff were still in the process of learning the job and, given the tempo, they were not in a position to lead the planning process. The solution involved a revised reporting arrangement whereby the Information Operations Officer reported directly to the Colonel Operations and the Commander INTERFET (COMINTERFET). The information-planning process thus commenced with COMINTERFET's guidance to the Information Operations Officer, who would then discuss concepts with the Colonel Operations and, if necessary, convene an information operations working group to conduct planning. While the information-planning cycle may appear to have been an ad-hoc arrangement, in reality it was a highly structured process, with the key staff—the Information Operations Officer, the Psyops Platoon Commander, the Public Affairs Officer and an intelligence representative—meeting daily.

### **Plans – Information Operations Relationship**

From the early stages of the operation, the Information Operations Officer identified the need for close involvement with the Plans Cell. It was this cell that provided the Information Operations Cell with advance warning of

operations and the development of contingency plans. The Information Operations Cell was always represented—generally by the Information Operations Officer—during the military appreciation process. This level of representation ensured that information operations were considered as an integral part of the planning process. The cell thus played a crucial role in the development of contingency plans, including those produced in anticipation of civil unrest in Dili and the mass return of internally displaced persons from West Timor. The close relationship with the Plans Cell was also crucial in ensuring that sufficient time was available for the Information Operations Cell to develop, pre-test, gain approval for, produce and distribute its material.

Once established, the Information Operations Cell became involved in all subsequent planning. This involvement highlighted the requirement for the Joint Planning Group to consider the use of information during the early phases of the planning process. It also reinforced the Deployable Joint Force Headquarters requirement for standing operating procedures governing the conduct of information operations, which, like doctrine, were conspicuous in their absence.

### **Strategic Guidance on Information Operations**

The successful conduct of information operations is dependent on sound guidance and direction. In the early stages of Operation *Stabilise*, the Strategic Command Division issued draft information operations guidance for comment by Headquarters INTERFET. A formal information operations directive from Strategic Command Division did not, however, eventuate. This lack of strategic guidance did not prevent INTERFET from conducting information operations. It merely meant that this level of direction and guidance to the Information Operations Cell was provided by COMINTERFET, who played an integral

role in determining information operations programs, priorities and end-states.

### **Information Operations Staff Planning Tools**

The key document for the conduct of information operations during Operation *Stabilise* was the synchronisation matrix. This document was used to display the approved themes and messages, and to indicate when they would be disseminated, by what means and to whom. It provided an excellent means of ensuring that the information operations effort was coordinated.

The matrix clearly indicated whether a message would be disseminated by leaflet, raised during a press conference, or mentioned on the weekly radio program. It also confirmed whether there would be an article on the subject in the weekly newspaper, or whether dissemination would be effected using all the available means.

The synchronisation matrix displayed details of information operations assets including psyops products such as leaflets, posters, loudspeakers and radio messages. It included information on the newspaper, and public affairs events such as media conferences and media releases. The matrix also outlined the involvement of assets such as the manoeuvre units and the planned use of civil–military operations.

The matrix was signed off by the Colonel Operations and issued as a fragmentation order. This authorisation ensured that the relevant organisations and units were tasked through the Operations Cell—a crucial point, since the Information Operations Cell did not have a command or control relationship with any force elements. The Information Operations Cell reviewed the matrix daily and updated it as required, in order to meet changing priorities

and to include new themes and messages. Table 1 illustrates the synchronisation matrix; the numbers refer to the key messages.

Ser	Method/Category	27 Oct.	28 Oct.	29 Oct.	30 Oct.	31 Oct.
(a)	(b)	(c)	(d)	(e)	(f)	(g)
<b>Psyops</b>						
1	Leaflets, Posters, Loudspeaker and Radio Messages	1-4, 6 and 10				
<b>Public Affairs</b>						
2	Media Conferences	1-4			10	
3	Media Releases					
4	<i>New East Timor</i>					10
5	<b>Civil Affairs</b>					
6	Contact with Locals, NGOs and Community Organisations	1-4				
<b>Manoeuvre</b>						
7	Dili Command	1-4, 5 and 10				
8	WESTFOR					
9	RESFOR					
10	Eastern Forces					

**Table 1: Synchronisation matrix**

The matrix proved to be one of the most important and powerful information tools. It facilitated the synchronisation of all assets while ensuring that themes and messages were conveyed effectively. The matrix required constant monitoring and was most effective when issued by the Operations Cell as a fragmentary order, tasking units or assets to conduct particular activities.

## DYNAMICS OF THE INTERFET INFORMATION CAMPAIGN

### Programs, Themes and Messages

The programs, themes and messages approved by COMINTERFET constituted the foundation on which the information campaign was built. It was critical to have all themes and messages approved at the highest level if the force was to recognise, respect and adopt them as a whole. Mixed messages represented a critical vulnerability for the information campaign in particular and for INTERFET as a whole. Previous information campaigns had recognised high-level messages as a central tenet in the employment of information operations, particularly SFOR in Bosnia, which expressed this principle as ‘speak with one voice’.<sup>22</sup> A comment by *Newsweek* further reinforces this point: ‘NATO’s varying pronouncements [on an incident during Operation *Allied Force*] hurt its credibility far more than Milosevic did’.<sup>23</sup> Elements within the region that wished to undermine the efforts of INTERFET could have exploited mixed messages, crippling vital credibility.

The key programs approved initially by COMINTERFET involved the issues of force protection, humanitarian assistance, peace promotion, and law and order. As the operation developed, COMINTERFET approved additional programs, including the return of internally displaced persons; anti-militia and anti-vigilantism; and the transition to the United Nations Transitional Administration East Timor (UNTAET).

---

<sup>22</sup> LaBahn, *op. cit.*, p. 34.

<sup>23</sup> ‘Casualties of War’, *Newsweek*, 26 April 1999, pp. 26–9, cited in Pounder, *op. cit.*, p. 57.



While the programs were consistent throughout East Timor, the priority designated by INTERFET to each program changed as necessary to support the operations current at the time. Initially, as forces were deployed into Dili, force protection was the priority. Over time, information operations resources residual to the force protection effort were channelled into areas such as law and order, and peace promotion. At the same time, in other regions in which INTERFET troops were first deploying, force protection once again assumed the highest priority.

It was the responsibility of the Information Operations Cell to monitor priorities by region throughout the operation and recommend changes in priority to COMINTERFET. Occasionally, when potential problems arose, information operations products of a force protection nature were reissued to reinforce this aspect. One such incident involved local residents protesting against the manner in which UNTAET was recruiting East Timorese. INTERFET troops were then caught up in the ensuing low-level violence. In this instance, leaflets and loudspeakers were used to remind the local population that INTERFET would not tolerate the use of violence against its troops.

The themes and messages provided the framework for the information campaign. As such it was critical that they were under continuous review and assessment as to their relevance to, and acceptance by, the target audience. Further planning involved the delivery means by which the themes and messages reached their intended target audiences. During the basic planning cycle, the Information Operations Cell addressed the following questions:

- What does the information campaign theme aim to achieve?
- What messages will facilitate the achievement of the campaign's aims?

- What is the target audience?
- What is the best method of delivering a message?
- How will the effectiveness of the message be measured?
- How will the effectiveness of the delivery means be measured?

Table 2 illustrates the use of an overarching theme and the dissemination of its associated messages. In this case, force protection is the theme and the associated messages include INTERFET's ability to protect its personnel and equipment. Measures for dissemination and for gauging the effectiveness of the message are also detailed.

Aim	Maximum force protection, minimal casualties.
Messages	INTERFET is highly capable; it will protect its people and equipment; do not threaten or harass INTERFET personnel.
Target audience	The population of East Timor.
How are messages communicated to the target audience?	Leaflets, posters, loudspeakers.
How will the effectiveness of the messages be measured?	Lack of threats against, or violence towards, INTERFET; respect for INTERFET; acceptance of INTERFET.

**Table 2: Force protection**

Given COMINTERFET's role as the approving authority, formations forwarded requests for themes and messages unique to their area of operations to the headquarters for approval. Once approved, the program, theme or message would be added to the information operations program and theme matrix.

Table 3 provides an example of the matrix.

<b>Program</b>	<b>Theme</b>
<b>Force Protection</b>	Futility of hostile actions against INTERFET.
	INTERFET's deployment to the Western Regencies is to facilitate humanitarian assistance.
	INTERFET will always respect the East–West border.
	INTERFET is truly multinational and is acting in accordance with a United Nations mandate.
	INTERFET is well trained, well equipped and well led.
<b>Peace Promotion</b>	Look to the future.
	Participate in the building of a new East Timor.
	Promote family and lifestyle.

**Table 3: Theme matrix**

As a multinational force, INTERFET had to ensure that all contributing nations were fully briefed and constantly updated on the programs, themes and messages. National commanders were briefed on the information campaign by the Information Operations Cell as soon as they arrived in East Timor.

## Psychological Operations

These operations, commonly known as psyops, are widely recognised as one of the mainstays of any information campaign. The SFOR information operations planners labelled psyops one of the ‘big guns’ of information warfare, along with civil affairs and public affairs.<sup>24</sup> The Psyops Platoon of the Military Intelligence Support Company provided the majority of the information material during Operation *Stabilise*. The platoon commander was one of the key information operations staff officers, although he did not work on the headquarters and had command responsibilities for his platoon. In effect he worked directly to the Information Operations Officer, who could task, assign priorities and direct the level of activity. The Information Operations Officer was responsible for ensuring that the Officer Commanding the Military Intelligence Support Company was informed of tasking, although the latter did not otherwise interfere with the process.

As the Information Operations Officer had no technical training in psyops, the platoon commander provided him with extensive and detailed advice on all psyops matters. The Psyops Platoon Commander and the Information Operations Officer developed the themes and messages for approval by COMINTERFET. Once a message was approved, the Psyops Platoon developed the final information products for dissemination. The product approval process took time since it was critical that each product underwent extensive pre-testing to ensure its accessibility to the local population. Each product was issued in three languages: English (for the approval process), Bahasa, and Tetum (the local language). Once the product had been successfully pre-tested, it was passed to the

---

<sup>24</sup> LaBahn, *op. cit.*, p. 32.

Information Operations Officer for progression through the approval chain to COMINTERFET. Product approval would generally occur within twenty-four hours and, once approved, the product was returned to the Psyops Platoon for production and dissemination.

### **Monthly Reports**

From the outset of Operation *Stabilise* the media expressed great interest in figures and statistics, ranging from the number and origin of personnel to the number of vehicles involved in the operation. Given the potential for the development of a strong relationship between the media and INTERFET, the Information Operations Cell developed and compiled a monthly unclassified situation report that covered a range of issues of interest to the media. These issues included troop numbers by nationality; key events and incidents during the month; and weapons handed in or captured. The broad range of topics also involved logistics updates, including figures such as tonnages; civil–military operations; internally displaced persons; and visits.

The cell worked closely with the Combined Public Information Centre in order to exploit opportunities such as the return of the first organised group of internally displaced persons from West Timor. The success of this initial repatriation demonstrated to the international community the good work being done by INTERFET and its ability to liaise closely with humanitarian organisations. The cell specifically targeted the international community, organising dedicated helicopter support for the media to move to Batugarde and witness the return of the internally displaced persons. The preparation of press releases prior to the event by the Public Affairs Officer reflected the synchronised effort behind the repatriation.

The manoeuvre forces on the ground, the air component (which provided the air assets), civil–military operations, non-government organisations (NGO), the Public Affairs Cell and the Information Operations Cell all worked together to achieve the desired outcome. The international media carried pictures of INTERFET troops, including the image of an Australian soldier carrying an elderly woman to an Australian Defence Force vehicle. This image, in particular, left a powerful and lasting impression on those that saw it. On this occasion, the information campaign had achieved its objective.

At all times the Information Operations Cell had to be aware of the risk of a potentially damaging counter-information campaign that would exploit opportunities to discredit the INTERFET information operations plan. Public information had to be accurate and reliable. INTERFET quickly established the importance of substantiating media and other disparate claims. INTERFET planners had to consider the need for media access to particular areas of interest, allocating transport to journalists whenever such a need arose. The importance of providing this type of support soon became obvious. The other major threat to credibility involved ambiguous or contradictory information. Consistency was paramount, and thus, throughout the operation, INTERFET exercised tight control over who was authorised to speak as its official representative.

### **Monitoring of International Media Reporting**

As a result of the violence preceding the deployment of the multinational force, the information infrastructure within East Timor was either destroyed or rendered inoperable. Newspapers were no longer printed; radio stations had ceased broadcasting; telephone networks were

unserviceable;<sup>25</sup> Internet connectivity did not exist; and no printing facilities were available. In effect, East Timor was in an information vacuum. Word of mouth was the only way of transmitting information, and that was unreliable and often inaccurate in its content. While the lack of infrastructure was a major obstacle to the transmission of information, it also provided INTERFET with a unique opportunity to guarantee the provision of accurate information to the local populace. An obvious source of information lay in the international media, present in East Timor in large numbers; however, their concern lay solely in catering to the international community.

The staff at the INTERFET Information Operations Cell soon realised that public information was an operational tool that had to be managed and controlled: ‘Everyone—commanders, information operations specialists, and public affairs officers—needs to understand public information is a battle space that must be contested and controlled like any other’.<sup>26</sup> The alternative was ‘leaving the [public information] battle space to either chance or the enemy’.<sup>27</sup> Although INTERFET enjoyed a positive relationship with the international media, examination of media reporting of the events in East Timor was crucial.

Generally, media reporting was accurate and reliable, although there were examples of blatantly and deliberately false and misleading accounts. Some false reporting was

---

<sup>25</sup> For the first six days of the operation, the INTERFET forces were able to rely on mobile phones until the links ceased to operate. They then used satellite phones until these links were restored. No domestic telephone infrastructure existed for use by the local community.

<sup>26</sup> Colonel J. Ivy, cited in Pounder, *op. cit.*, p. 60.

<sup>27</sup> Pounder, *loc. cit.*

crude and easily countered, while others were more elaborate attempts to deceive or discredit INTERFET. Perhaps one of the most infamous reports of this type was the alleged activity in Licquica involving the militia leader Eurico Guterres. This report attempted to lend the perception that INTERFET could not provide security in East Timor and that the militia groups could operate with impunity. This incident required careful management since it attracted considerable media attention, with many news agencies demanding answers from INTERFET. In the end INTERFET discredited these claims, and careful management by COMINTERFET and the Combined Public Information Centre defused a potentially damaging incident.

As part of the United Nations High Commissioner for Refugees (UNHCR) mass-information campaign in West Timor to assist in the return of internally displaced persons, Indonesian journalists were brought to East Timor to see the security situation for themselves. While in Dili they interviewed COMINTERFET. These interviews, coordinated by the Public Affairs Officer, were crucial in reflecting INTERFET in a positive light.

The vital importance of winning the media war is nowhere more ably demonstrated than during Operation *Allied Force* in the former Yugoslavia. During this campaign, Serb propaganda proved a lethal force in the information battlespace. NATO forces reached the stage where they felt they had exhausted all options and 'eventually began bombing the facilities of RTS . . . the Yugoslav state-owned radio and television service. Results from these attacks were decidedly mixed: RTS returned to the airways in a matter of hours and NATO received sharp criticism for targeting



journalists'.<sup>28</sup> This extraordinary action led some to question whether this information campaign had, in fact, failed.<sup>29</sup>

A number of incidents throughout Operation *Stabilise* received significant media attention and tested the ability of INTERFET to respond. While the method of response was determined at the strategic level by COMINTERFET, the Information Operations Cell provided him with a number of tools to assist in the dissemination of the INTERFET message. One of the first incidents that excited widespread media attention concerned the reaction of several Asian nations to the initial *modus operandi* of the Australian-led INTERFET force. Critics accused Australian soldiers of being 'heavy-handed' in their apprehension of suspected militiamen.<sup>30</sup> Footage of Australian soldiers pointing weapons at the heads of these suspects was beamed around the globe and appeared on the front pages of many leading international newspapers.<sup>31</sup> At the same time, reports appeared to indicate significant differences in opinion over the handling of the INTERFET operation, raising doubts over the future cohesiveness of the disparate INTERFET force. Some Asian leaders accused the Australian Government of being 'pushy' and unduly interfering in the region.<sup>32</sup> INTERFET was faced with one of its first crises: the challenge of establishing its credibility in front of a questioning international audience.

---

<sup>28</sup> *Ibid.*, p. 72.

<sup>29</sup> Colonel (Select) J. Ivy, US Air Force, cited in Pounder, *op. cit.*, p. 72.

<sup>30</sup> K. Liang, 'Asia's Angst Over Timor Intervention', BBC news report dated 28 September 1999, p. 2.

<sup>31</sup> The BBC, the *Jakarta Post*, *Asia Times*, the World Socialist Website and *Time Asia* all carried this story, most with photos of Australian soldiers and alleged militiamen.

<sup>32</sup> *Ibid.*

As part of a carefully crafted response, COMINTERFET utilised the full range of information operations products to reinforce the message of friendship and the strength of the relationship between the East Timorese and the INTERFET soldiers. The INTERFET message emphasised the importance of creating a secure and stable situation that would provide the necessary climate for reconstruction. INTERFET's objectives, and thus those of the information campaign, included the maintenance of the coalition. The INTERFET response to allegations of division within the multinational force was to highlight the strength of the coalition, particularly through the newspaper, the *New East Timor*. The Information Operations Cell worked hard to ensure that the newspaper was not, and was not seen to be, a purely Australian product. It became a forum that effectively reinforced coalition cohesion through emphasis on the contributing nations as essential members of the team. The cell sought contributions from all nations and made every effort to portray the coalition as united and committed.

While the international media carried a succession of INTERFET stories throughout the operation, most portrayed the mission in a positive light, recognising the necessary, often unpleasant, but highly valuable nature of the operation. Inevitably, however, there were reports alleging unacceptable behaviour by INTERFET members. Such reports had the potential to be extremely damaging; one was so serious that COMINTERFET himself found it necessary to discuss the allegations with the media organisations. Allegations involved the torture of detained militiamen by INTERFET soldiers, including the taking of 'trophy' photos of dead militiamen.

Given the grave nature of these accusations and the possibility of interest by organisations such as Amnesty

International and the Red Cross, INTERFET was required to address the allegations immediately in order to protect its all-important international reputation. The consequences for programs such as efforts to persuade militia groups to surrender and embrace the process of reconciliation were potentially disastrous and were averted only by careful handling. The ramifications of such negative publicity for both UNHCR and the reconciliation process that Xanana Gusmao was, even at that early stage, piecing delicately together, were potentially ruinous.

The return salvo fired by INTERFET comprised assurances by COMINTERFET that these allegations were being treated very seriously and that a detailed investigation was in progress. COMINTERFET stated publicly that, were the allegations proven, the penalties for anyone implicated would be extremely severe. The underlying theme of the INTERFET message was the value that COMINTERFET, in particular, placed on the good reputation of the Australian soldier. ‘We worked very hard there to establish a great reputation and our soldiers continue to do wonders . . . we abhor that sort of behaviour’, he told various media agencies.<sup>33</sup> The Prime Minister weighed in with his support, stating publicly that this sort of behaviour was ‘not the Australian way’.<sup>34</sup> These statements were disseminated widely among the international media by INTERFET to emphasise the importance it placed on the good reputation of its soldiers and the good faith of the people of East Timor and the international community.

---

<sup>33</sup> South Africa Press Association report of 1 November 2000. Downloaded from news24.com at website: <[http://www.news24.com/News24/World/Australasia/0,1113,2-10-36\\_934182,00.html](http://www.news24.com/News24/World/Australasia/0,1113,2-10-36_934182,00.html)>. This report was also carried by the ABC, the *Advertiser*, the *Jakarta Post* and the *Observer*.

<sup>34</sup> South Africa Press Association report, *ibid*.

A third highly sensitive issue that serves to illustrate the complexity of the information operations task involved the return of Xanana Gusmao. This was an event that inevitably attracted considerable media interest. While most media organisations concentrated on the significance of his return, a number of agencies also raised questions concerning the fact that he arrived on an Australian C-130 military aircraft, flanked by sunglass-clad Australian Special Air Service (SAS) troops and wearing the camouflage fatigues of the Falintil guerilla movement. COMINTERFET was very conscious of the perception that Gusmao's return could create and engineered a response designed to dispel the notion that INTERFET was in any way biased towards Falintil. Information operations products provided a necessary component of this response with printed matter, particularly the *New East Timor* newspaper, continuing to disseminate the theme of INTERFET impartiality.

### **Civil Affairs**

The role of the civil affairs organisation is to build a relationship between the local community and forces such as INTERFET. The local community incorporates elements such as the civil authorities, local civilian organisations and NGOs. Civil affairs comprise a crucial element of any information campaign in the provision of grassroots data on the local population, supplying vital information to the forces concerning trends and perceptions within the local community. Civil affairs officers also bridge the communication gap, providing daily liaison, and engendering support for forces such as INTERFET. These officers were allocated a number of messages for daily meetings held with representatives of the NGOs. These messages generally related to reconciliation, anti-vigilantism and peace promotion.

While civil affairs were incorporated into the information operations plan throughout Operation *Stabilise*, the reality was that INTERFET did not fully exploit the civil affairs role in information operations. Too often, INTERFET missed the opportunity to collect valuable information through its civil affairs officers. The useful information that INTERFET did collect was often not passed on through the INTERFET network to those who could have utilised it. Civil affairs officers could have requested feedback from NGO workers, for example, who may have had detailed knowledge on how successful INTERFET was in communicating its message to the local population. This feedback would have been an invaluable planning tool for the INTERFET Information Operations Cell.

The cell was also desperate for crucial information to assist in measuring the effectiveness of its products. This information included such issues as whether the newspaper, the *New East Timor*, was assisting the aid effort. The cell was particularly eager for information that would indicate the level of community understanding of the current political situation. The transition program was another issue of concern. The cell was keen to assess the extent to which the local community understood the projected program for transition from INTERFET to UNTAET. NGO field workers could have provided much of this feedback. The sensitivity of the situation dictated, however, that the cell be both subtle and transparent in its feedback collection methods, lest its motives be misunderstood and its credibility suffer. Its primary focus lay in the dissemination of the INTERFET message and its role in achieving the broader INTERFET objectives.

## Public Affairs

The public face of Operation *Stabilise* was crucial to the success of the entire operation. The Public Affairs Cell provided the means by which the Australian public, international audiences, and even the soldiers themselves, accessed information concerning INTERFET. In General Sullivan's words,

If information is 'the currency of victory on the battlefield', then public affairs—through its public information mission—can clearly supply some of the capital for winning the media war (as part of the information campaign) and can bolster public support for the overall military effort.<sup>35</sup>

The Public Affairs Cell provides a further mechanism by which the commander controls the information battlespace. It also enables him to present the human face of an operation, often a powerful weapon in the fight against adversary disinformation and propaganda. One of the criticisms levelled against the information operations planners in US Operation *Allied Force* is the lack of personalisation and absence of the human factor. As one military commentator asked, 'Where were the successes? Who were the heroes, the soldier, sailor, or airman who helped a family or a refugee?'.<sup>36</sup> A *Washington Post* journalist observed: 'By staying quiet, they denied those involved their due for their heroism and bravery. We saw few of the individual faces and missed their particular stories . . . Consequently, the public was much less engaged—essentially not invited to the war'.<sup>37</sup> The human face of the mission to East Timor was one aspect that INTERFET exploited to its maximum potential.

---

<sup>35</sup> General G. Sullivan, US Army, cited in Pounder, *op. cit.*, p. 58.

<sup>36</sup> Lieutenant Colonel V. Sullivan, US Air Force (retd), cited in Pounder, *op. cit.*, p. 70.

<sup>37</sup> B. Graham, *Washington Post*, cited in Pounder, *op. cit.* p. 71.

Throughout Operation *Stabilise*, the Public Affairs Cell supported the information operations plan primarily through the daily press conferences. These conferences provided the ideal platform for INTERFET to pass key messages to the media. The responsibility for addressing the media was shared between COMINTERFET and his Chief of Staff. Throughout the operation they were the only people that addressed the media on a regular basis. The special relationship that existed between the media and COMINTERFET was a crucial element in the information campaign. While the Chief of Staff was the regular spokesperson, the presence of COMINTERFET at a press conference attracted added attention as it came to signify an important announcement or message.

Each day the Information Operations Officer and the Public Affairs Officer would meet to determine how the press conference could be best used to shape the information environment. During the evening, they would review the press reports to determine the success of the message transmission and to assess the effectiveness of the message itself.

The press conferences were also a forum in which the INTERFET hierarchy could refute counter-propaganda and disinformation. Not all misinformation was refuted, since responding could potentially lend it some credence; whereas, if it were simply ignored, it quickly disappeared. Disinformation required close observation to ensure that, if a response were necessary, it was provided quickly and accurately by the appropriate authority in INTERFET.

Accurate reporting was not always the hallmark of press coverage, and there were cases of incidents being grossly misreported by various media outlets. Such misreporting was used on occasion by militia groups to intimidate

internally displaced persons and supported the anti-INTERFET propaganda spread throughout the camps.

The Combined Public Information Centre's main task was to ensure the best possible coverage of Australian Defence Force troops deployed on operations. To that end, it did not see itself as part of the information operations plan. This is symptomatic of a doctrinal impasse that, until it is resolved, makes it unlikely that all assets will be truly synchronised. The provision of information operations products must be a priority for both the Combined Public Information Centre and the Information Operations Cell, and the crucial nature of this synchronisation cannot be underestimated.

### **Disinformation**

INTERFET found that the use of disinformation constituted a major source of concern. The disinformation campaign faced by the Information Operations Cell comprised largely rumours and allegations aimed at undermining INTERFET objectives. It was beyond the means of the cell to address every rumour or allegation aimed at INTERFET, and it was certainly not COMINTERFET's intention to do so. There was some evidence of an orchestrated campaign targeting various elements of the population, including internally displaced persons and relatives of the militiamen.<sup>38</sup>

The purpose of disinformation in places such as the camps in West Timor appeared to be to persuade internally displaced persons not to return to East Timor. Disinformation played on their personal security fears, for example, by spreading

---

<sup>38</sup> A visitor to the internally displaced persons' camps told me that militia leaders had been seen speaking to large groups. I was also shown photos depicting these meetings, which appeared well organised and even utilised public-address systems. (Author's note)



rumours of atrocities by INTERFET soldiers on returning refugees or by implying that INTERFET would be unable to protect them from marauding militia groups. This was certainly the case when allegations arose concerning the alleged activity in Licquica by militia leader Eurico Guterres. Similarly, disinformation sought to persuade militiamen not to surrender, once again for reasons of personal safety.

The Information Operations Cell sought to counter this disinformation through a variety of forums, including the international media and contact with the local population. Psyops products maintained a consistent theme of safety and security. A video was produced by INTERFET to support the UNHCR mass-information campaign. The video focused in particular on the close and friendly relationship between the local community and members of INTERFET. Bishop Carlos Belo delivered the narration, lending the footage credibility. The information campaign targeted militiamen and their relatives in leaflet drops around areas they had been known to frequent.

## **Deception**

As Winston Churchill once observed, ‘In wartime, truth is so precious that she should always be attended by a bodyguard of lies’.<sup>39</sup> A component of IO, deception was treated very cautiously during Operation *Stabilise*, with the advantages carefully weighed against the disadvantages. As LaBahn observes: ‘IO must continue to focus on truth projection and informing the population. These are always key tasks

---

<sup>39</sup> Sir Winston Churchill, cited in General R. Fogleman, US Air Force, ‘Information Operations: the Fifth Dimension of War’, remarks to the Armed Forces Communications–Electronics Association, in *Defense Issues*, vol. 10, no. 47, February 1996, p. 2.

because . . . tensions are easily inflamed by disinformation, propaganda and ignorance'.<sup>40</sup>

The reality was that, having used deception once, INTERFET would, from that point, struggle to retain the confidence of the local population. Once the trust of the local population was lost, it might have proven almost impossible to regain. In the end, the Information Operations Officer, in consultation with other staff, decided that deception was not a valid component of information operations for Operation *Stabilise*. COMINTERFET issued his own guidance on the issue when he stated that, at all times, INTERFET must be, and must be seen to be, credible and capable.

### **Security and Information Operations**

The security of operations was a major concern to the Information Operations Cell. Most of the available military information was classified so that it remained accessible only to members of INTERFET. In stark contrast, the information campaign relied on providing vast amounts of information to the population.

To guarantee that operations security was at no stage breached, each product had to be checked to ensure that it was not providing information that could be used to attack INTERFET operations. The Colonel Operations was responsible for confirming that each product was cleared for operations security purposes. This level of clearance was potentially problematic for the Information Operations Cell since its products often had to be prepared in advance so that they would be ready for release at the correct time. Two instances of the impact of operations security on information stand out.

---

<sup>40</sup> LaBahn, *op. cit.*, p. 37.

The first of these instances concerned Operation *Lavarack*, the deployment of the 3rd Brigade to the border regions. This operation had the potential to attract significant media attention. The timing and details, however, were barred from release prior to a designated time. As part of the Operation *Lavarack* information operations plan, a press release was prepared for COMINTERFET, along with a list of possible questions and answers to be issued to the media at an appropriate time.

The operations security plan was completed successfully and was synchronised with other aspects of the information campaign. To enhance the operation further, helicopters were organised prior to its commencement to take media representatives to the region. The end result was that operations security for the deployment was achieved and INTERFET was well prepared to provide detailed information to the media. Press reports on the ability of INTERFET to conduct a large and rapid build-up in the Western Regencies were uniformly positive. This positive reporting helped to shape the environment and support COMINTERFET's key message on the effectiveness of INTERFET.

The return of Xanana Gusmao to East Timor provided another example of the role of operations security in the information operations plan. While the imminent return of Gusmao was common knowledge, his exact time of arrival was not made public for obvious security reasons. The Information Operations Cell's conundrum lay in preserving the secrecy of his arrival time while ensuring maximum attendance at his first public address only hours after his arrival. The cell resolved the matter through the advance preparation of leaflets and loudspeaker messages, both approved and produced the day before. Two hours before the address by Gusmao, INTERFET distributed leaflets and

conducted loudspeaker broadcasts throughout Dili, inviting locals to attend. The information operations plan was successful: there was a large public turnout at the address and, importantly, operations security was maintained despite the fact that material had been prepared in advance.

## **RELATIONS WITH OTHER ORGANISATIONS**

### **INTERFET's Relationship with United Nations Agencies and NGOs**

Harmony and cooperation have not always marked the relationship between peacekeepers and NGOs. Some disagreement has been apparent during operations in areas such as Bosnia, indicative of a clash of ideas and a conflict of objectives. This disagreement was inevitable given that the two operated within vastly different parameters. As John Mackinlay has pointed out, 'The "marriage" bargain was quite clear: the humanitarian elements had the central role of relief and development; the military only remained for as long as necessary to provide security support to the stabilization process'.<sup>41</sup>

COMINTERFET's intention was to create a healthy and cooperative relationship between INTERFET and the NGOs present in East Timor in order to further the interests of both parties. Support to the NGOs and to United Nations agencies such as the United Nations International Children's Emergency Fund and UNHCR was organised through the INTERFET Civil-military Operations Cell in Dili.

---

<sup>41</sup> J. Mackinlay, 'NGOs and Military Peacekeepers: Friends or Foes?', in *Jane's International Defense Review*, vol. 30, July 1997, p. 51.

In terms of the information campaign, COMINTERFET directed the Information Operations Cell to provide full support to the UNHCR mass-information campaign in order to encourage internally displaced persons to return to East Timor. The militia groups had subjected the internally displaced persons to significant physical and psychological intimidation, and had denied them accurate and reliable information on the current situation in East Timor. UNHCR was the lead agency for their repatriation and worked closely with the International Organisation of Migration, which conducted the organised returns.

INTERFET's direct contribution to the campaign included:

- the production of a video comprising an address by Bishop Belo and scenes from East Timor showing food distribution, markets, and the role of INTERFET; and providing a visual reassurance on the security situation;
- the provision of the *New East Timor* newspaper in both hard copy and electronic form. UNHCR reproduced some articles from the newspaper in its own information sheets; and
- the provision of radios and batteries to UNHCR. INTERFET provided over 200 radios to UNHCR for distribution. UNHCR was broadcasting from radio stations that were capable of reaching the internally displaced persons' camps close to the border.

As the only newspaper in the country, the *New East Timor* was made available to the NGOs that wished to provide information to the population. NGOs were encouraged to submit articles and photos demonstrating their achievements and providing information on future projects. They were also asked to articulate programs, priorities and projects for the benefit of the East Timorese people.

## **Relationship with Church Groups**

The Church, and in particular the Catholic Church, is a strong influence in the lives of the East Timorese. It permeates all aspects of society, with religious leaders such as Bishop Belo attaining significant status within the community. INTERFET was able to establish a strong link with the Church, which assisted in the dissemination of public information to the community. Each week the Information Operations Cell would provide the padre on Headquarters INTERFET with a large quantity of newspapers for distribution to different parishes.

## **Relationship with UNTAET**

The Information Operations Cell's relationship with UNTAET developed throughout the operation. In terms of information dissemination, UNTAET's primary focus was on the establishment of a radio station in Dili. As a result, UNTAET produced little written material throughout the period INTERFET was deployed. The lack of such material placed an additional burden on INTERFET since it had to produce printed material for UNTAET as well as for its own purposes. INTERFET also permitted the broadcasting of items from the *New East Timor* on Radio UNTAET since the newspaper provided regional news from around East Timor that UNTAET could not source in any other way. INTERFET provided other such assistance to UNTAET, including copies of interviews with key personalities so that UNTAET would not have to conduct its own interviews.

As the time for the handover to UNTAET drew closer, the Information Operations Cell commenced work on developing the products to support the transition program. There was significant concern in the community that the security situation would deteriorate when INTERFET left. To ensure that there was a common message about the

transition, INTERFET and UNTAET undertook the transitional product development jointly, using INTERFET resources. Figure 1 is an example of a combined UNTAET–INTERFET product.

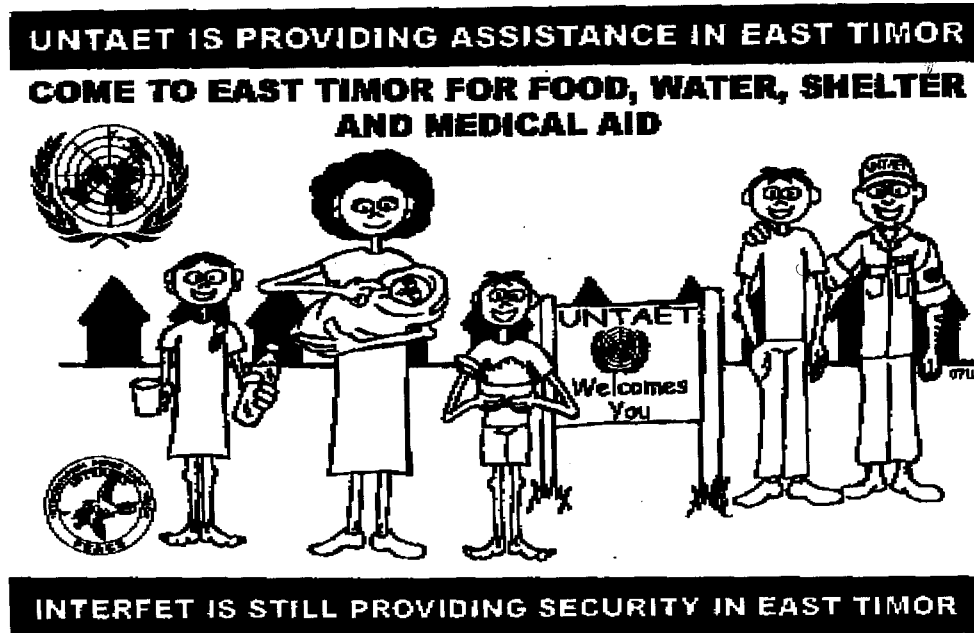

**Figure 1: Example of an INTERFET–UNTAET leaflet**

## INFORMATION OUTPUTS

### Program and Product Summary

Table 4 lists the number of products that the Information Operations Cell produced and distributed during Operation *Stabilise*. They are catalogued by type and program.

<b>PRODUCT TYPE</b>	<b>No. of Products</b>	<b>Total Produced by Type</b>
<b>Leaflets</b>		1 216 299
Force Protection	19	
Law and Order	6	
Anti-militia	18	
Humanitarian Assistance	8	
Peace Promotion	5	
Transition	5	
<b>Posters</b>		55 000
Force Protection	6	
Law and Order	10	
Humanitarian Assistance	3	
Peace Promotion	6	
Transition	3	
<b>Loudspeaker</b>		56
Force Protection	16	
Law and Order	6	
Anti-militia	2	
Humanitarian Assistance	4	
Peace Promotion	2	
Transition	2	
<b>Radio</b>		33
Force Protection	4	
Law and Order	3	
Anti-militia	10	
<b>Video</b>		
Return of internally displaced persons	1	20
<b>Newspaper</b>		
<i>New East Timor</i>	14 editions	410 000

**Table 4: Product summary**



The demand for printed products was extremely high. The logistic system was hard-pressed to meet the demand for ink, printing plates and paper. For future information campaigns, it is imperative to ensure that initial stocks of these items are sufficient to allow the conduct of operations until resupply systems are capable of meeting this demand.

### **INTERFET Newspaper**

Shortly after the commencement of Operation *Stabilise*, the Information Operations Cell identified the need to produce a regular, reliable, informative and widely circulated newspaper. Within four weeks of arriving in East Timor, INTERFET distributed the first edition of the *New East Timor* to the local people. In time, it was to prove to be the most important information product utilised by INTERFET.

The newspaper was produced on a weekly basis, with 35 000 copies being printed on the 1st Topographical Survey Squadron offset printer in the back of a Unimog truck. Of these, approximately 20 000 copies were in Tetum, 10 000 in Bahasa and 5000 in English. The papers were distributed to all thirteen regions of East Timor, including the Oecussi Enclave. The content of each issue was determined by the Information Operations Officer, Psyops Platoon Commander and public affairs planner (also designated editor) in accordance with the synchronisation matrix. Stories and articles that supported programs, themes or messages were sought from INTERFET formations, units, NGOs, UNTAET and key community leaders.

The production of the newspaper was a large task for INTERFET to undertake, particularly given the small number of personnel allocated to its production. The newspaper team's structure is shown in Figure 2. The team comprised:

- the publisher (Information Operations Officer), who was responsible for the overall production and distribution of the paper;
- the editor (Public Affairs Officer), who was responsible for assisting in the selection, compilation and proofing of articles; and
- the adviser (Psyops Platoon Commander), who was responsible for assisting in the selection of key messages, themes and articles for the newspaper; overseeing the desktop publishing of the articles; forwarding the completed product to the printers; and distributing the newspapers.

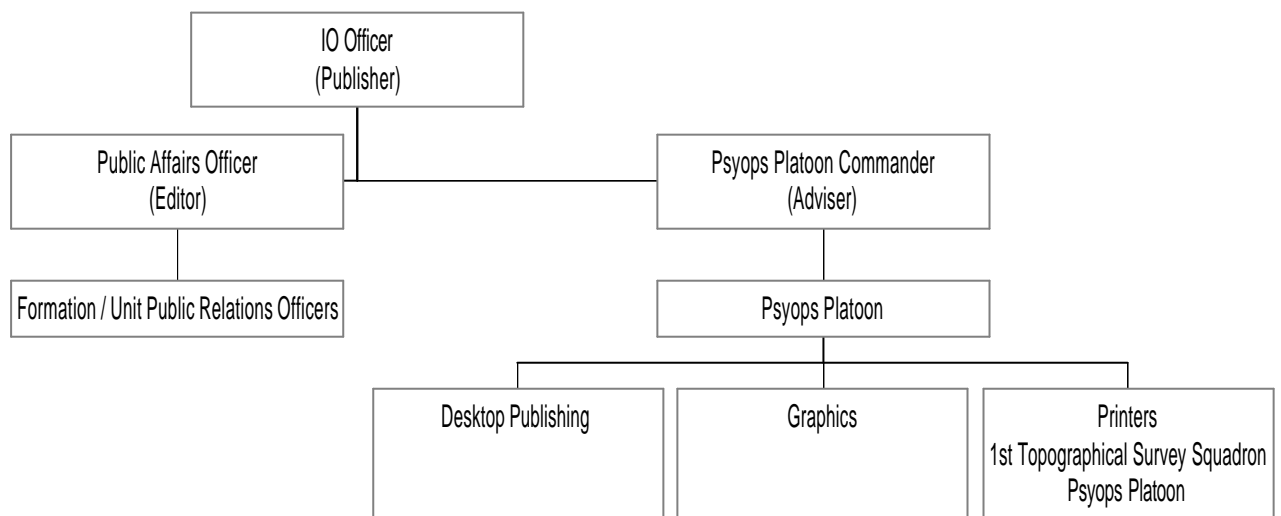

**Figure 2: Newspaper team structure**

The newspaper was produced in accordance with a tight time-line. A stringent deadline resulted from the need for copy clearance through the standard approval process, and the translation of articles into Tetum and Bahasa. The time-consuming printing process and the need to meet existing air-courier schedules only made the time-line

tighter. The aim was to have the newspaper widely distributed by each Sunday since this was the time when many East Timorese would gather in towns to attend church. To miss the Sunday morning gatherings risked not reaching a large part of the population.

Importantly, while the paper was used to highlight particular messages and themes, it always remained an accurate source of news and information. It included messages or interviews with key figures such as COMINTERFET; Bishop Belo; and Mr Sergio De Mello, the Special Representative of the United Nations Secretary-General. Other articles provided practical information on humanitarian assistance such as food distribution and vaccination programs.

The *New East Timor* was used to highlight the excellent work being done by INTERFET in rebuilding the infrastructure of the country, and this emphasis undoubtedly helped to build a strong relationship between the force and the local population. The paper also included regional and international news, and sporting results—particularly for soccer, which remains the most popular sport in East Timor. COMINTERFET used the paper to convey his key messages, as did other leaders. Photographs were an important aspect of the paper, and whenever possible, photographs of key personalities such as Xanana Gusmao, Hose Ramos Horta and Bishop Belo were included. For many East Timorese these were the only photographs that they had of their leaders, and it was not uncommon to see the newspaper affixed to buildings, trees and houses in place of the posters so familiar in Western societies.

As it was the primary source of information in East Timor, the paper became highly popular. It was used to raise the profile of UNTAET and allow it the opportunity to articulate

its plans, priorities and programs to the people. The role played by the paper became even more important as frustration among the local population grew in response to a perception that the establishment of UNTAET was proceeding too slowly.

The newspaper was designed to reinforce coalition cohesion through emphasis on the contributing nations as essential members of the team. Thus each edition contained articles from all contributing nations and highlighted a different country and the strength of its contribution. Each country was encouraged to provide its own articles, allowing readers broad freedom of choice.

The paper also provided news for the troops on what was happening throughout East Timor. Troops in Suai, for example, could read about the work being done in Los Palos or Baucau, thus heightening their awareness of the overall situation. NGOs were offered the opportunity to provide articles to the paper on a regular basis. This allowed them to explain what they had achieved to date and, more importantly, what they were planning to do. The newspaper was also used as a vehicle for early problem resolution. Increasing public resentment of an organisation could often be tempered by the newspaper's timely publication of good-news stories concerning that organisation.

The newspaper's effectiveness was nevertheless contingent on efficient distribution to the target audience (Figure 3). Initially the *New East Timor* was distributed using the traditional military chain of command; however, this method limited the newspaper to a portion of the population. The development of new networks was required to maximise the reach and influence of the paper. This development occurred over time,

and by the completion of the operation, the network had become quite sophisticated, as illustrated in Figure 4.



**Figure 3: The *New East Timor* being distributed in Dili**

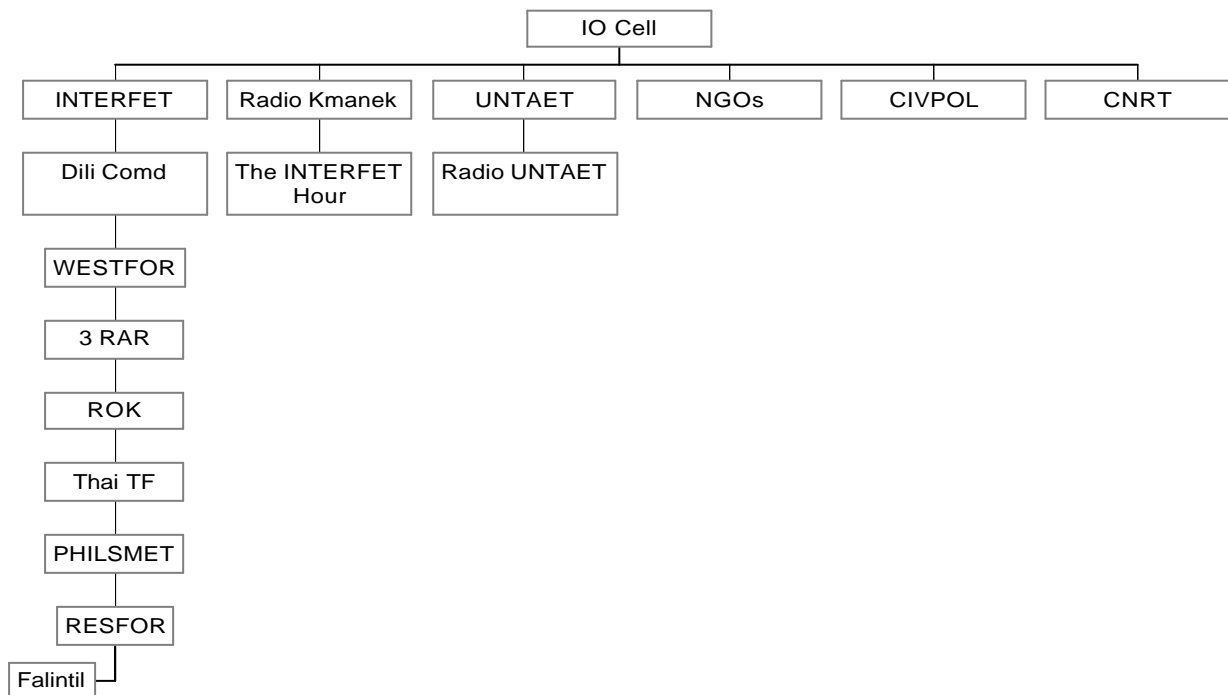

**Figure 4: The New East Timor distribution network<sup>42</sup>**

<sup>42</sup> CNRT refers to the National Council of East Timorese Resistance.

In Manatuto the distribution of the newspapers provided an opportunity for enterprising young boys to establish a newspaper run. Each week the boys would meet the aircraft that delivered the papers and then divide them into smaller bundles for delivery in their designated area. In other areas the paper was bartered for, even though it was free of charge.

Perhaps the value of the newspaper is best summarised by a comment from the Bureau Chief of Agence France-Presse in Jakarta, Bernard Estrade:

The *New East Timor* is history: it tells the history of independence for the people of East Timor as it occurred. The newspaper, a single sheet printed in black and white on both sides, has during the past four months been the only newspaper in East Timor giving local news and information, dominated by the activities of various non-governmental organisations.<sup>43</sup>

## Radio

During the violence prior to the establishment of INTERFET, the three radio stations in Dili were either closed down or destroyed. Soon after the commencement of Operation *Stabilise*, INTERFET and UNTAET assisted one of the radio stations, Radio Kmanek, to resume broadcasting. Radio Kmanek was a Catholic radio station and was the least damaged of the three stations. It was a popular station, and the Information Operations Officer rapidly identified it as potentially another medium through which to transmit information. Following negotiations between the Information Operations Officer and the radio station manager, the latter prepared a formal contract

---

<sup>43</sup> B. Estrade, 'New East Timor Newspaper Closes', Agence France-Presse via John Miller, <fbp@igc.org>, 25 January 2000, in *Pasifik Nius*, Pacific Media Watch, Journalism Programme, University of the South Pacific.

offering INTERFET the opportunity to purchase air time on the radio station. This offer was quickly accepted.

The concept for use of the radio station in support of the information campaign involved air time three nights per week. These slots were selected because the coverage was greater at night. The contract involved the station's broadcast of the contents of the weekly newspaper in Bahasa and Tetum. The news items were interspersed with popular music and the program lasted around one hour. This program later became known as the 'INTERFET Hour'. Interviews with key people such as COMINTERFET were also broadcast. At the end of each program, the station manager usually interviewed the Information Operations Officer on a range of current issues.

The interview was less structured than the rest of the program but provided an excellent opportunity to address the concerns of the local population. The Information Operations Officer, who was fully conversant with the themes and messages approved by COMINTERFET, highlighted these concerns during the interview. The interviews proved to be essential during the period leading up to the transition from INTERFET to UNTAET, since they enabled the general population to understand the process better.

The other component of the contract constituted a commitment that the radio station would play an unlimited number of community announcements throughout the week. These messages covered a wide range of information, such as advice to the people of Dili that there were changes to the traffic rules or that the police station had reopened. Radio Kmanek was also used to play specific messages intended to discourage militia groups from conducting further hostile

activities and to encourage internally displaced persons to return to East Timor.

The radio station proved to be a positive and important component of the information campaign since it provided a relatively large coverage of the population and could be used by INTERFET to transmit messages quickly. The Information Operations Officer also retained the flexibility to record live interviews at short notice, should the need arise.

While the radio programs elicited a positive response from the local population, the listening audience was limited because many of the radios in the community had been lost or destroyed during the violence. Despite this, the station manager was adamant that there was still a significant number of radios in the community and that information transmitted by radio was quickly conveyed to non-listeners by word of mouth.

The Information Operations Officer was determined to increase coverage and developed a plan for increasing the number of radios in East Timor. This initiative was undertaken as a cooperative effort with the radio station HOT FM in Tasmania. The station ran a campaign appealing for donations of radios for the people of East Timor. The campaign included live interviews with the Information Operations Officer during the morning radio programs to generate support. It was highly successful, and in a relatively short period of time, over 300 radios—many of them large enough to use in a community hall or hut—along with thousands of batteries, arrived in East Timor. They were distributed throughout the larger communities, with some short-wave radios being sent to the remote regions. Each short-wave radio had programming information, in both



Tetum and Bahasa, and frequencies for Radio Australia and the BBC World Service on laminated sheets zip-tied to it.

This campaign had an extremely positive effect on the operation: the East Timorese appreciated the goodwill of the Australian people; the soldiers felt tremendous support from their home country; and the target audience increased commensurately. Some radio cassette players were also donated to schools, representing a positive step in bringing INTERFET and the community closer together.

Towards the end of the operation the Information Operations Cell developed a talkback program focused on providing answers to questions raised by people in the local community. Questions were recorded by station staff and translated into English. After receiving the questions, the Information Operations Officer researched and provided answers on the weekly program. This program was popular precisely because it addressed the issues and concerns of the local people. It demonstrated that INTERFET was keen to ensure the provision of a forum in which the East Timorese could raise issues and have them addressed.

Each week the radio station provided a taped copy of the 'INTERFET Hour' to the cell. As the radio station did not cover all of East Timor, the cell copied the tapes and sent copies to those formations that were unable to receive the broadcasts, but which included a loudspeaker team within their elements. INTERFET units in these areas played the tapes over speakers positioned where large groups of people were gathered, for example, transit centres in Suai for those returning from West Timor.

UNTAET established its own radio station as the primary means of disseminating information to the public.

Agreement was reached between UNTAET and INTERFET that messages, be they articles from the *New East Timor* or community announcements, could be broadcast over Radio UNTAET. The Information Operations Officer and the Psyops Platoon Commander from the Information Operations Cell met regularly with the Combined Public Information Centre to discuss the key messages and themes that each would be using in the following week. The meetings allowed a degree of synchronisation between INTERFET and UNTAET, ensuring that the messages that they transmitted were consistent. Such synchronisation became extremely important in the period prior to transition, since it was vital that UNTAET and INTERFET spoke with a common voice.

Technical staff from UNTAET provided detailed maps of the radio coverage of the border region. These maps showed that, due to the topography, significant areas along the border were not covered, including those in close proximity to a large number of internally displaced persons' camps. A deployable radio station could have been used to cover these areas; however, the Australian Defence Force simply did not have the resources to fill this need. The Information Operations Cell viewed this as a wasted opportunity to transmit the INTERFET message to those in the internally displaced persons' camps.

## **Leaflets**

Throughout Operation *Stabilise*, INTERFET used leaflets extensively for psyops purposes and occasionally for public information. Over 1 200 000 leaflets were distributed between October 1999 and February 2000. The leaflets were mass-produced and delivered by hand, rotary-wing and fixed-wing aircraft. Rotary-wing aircraft were used in the border regions, including in the Oecussi Enclave. The

Psyops Platoon produced the leaflets, utilising its own resources and with the assistance of the 1st Topographical Survey Squadron.

As with other products, the key to a successful leaflet lay in the pre-testing (Figure 5). Pre-testing was critical to ensuring that the product had the desired effect. One leaflet that was shown to be misleading during pre-testing appeared to indicate that UNTAET peacekeepers would not be armed to the same degree as INTERFET, causing some concern to the East Timorese who participated in the trial. This trialling of material was a valuable lesson in the importance of pre-testing products. It served to make one become aware of differing perceptions produced by a particular message; it also demonstrated the danger posed by the ambiguities of language.



**Figure 5: Pre-testing psyops products**

Along with the differences in cultural perception, cultural awareness also presented a major challenge to the Psyops Platoon. On another leaflet, drawings depicting string puppets were used to convey a particular message. The leaflet was a dismal failure since the Information Operations Cell lacked the cultural awareness to recognise that string puppets did not form part of Timorese culture. The local populace found these images completely undecipherable. This is a common conundrum for most architects of information campaigns and, indeed, blissful ignorance of cultural and linguistic factors may spell doom for any information campaign. A case in point involves US operations in Somalia in 1993. General Zinni, commander of the mission tasked with the withdrawal of the UNOSOM II forces from Somalia, soon discovered that the level of illiteracy in that country was so high that political cartoons proved to be the only effective means of populist communication.<sup>44</sup>

The information campaign along the border with West Timor posed yet another significant challenge to the Information Operations Cell. In broad terms, the aim of the campaign was to neutralise the effect of the militia groups, separate them from their support base and isolate their leaders. It also aimed to encourage those militiamen who had renounced violence and were prepared to face justice to reconcile their differences in a peaceful manner so that they could return to East Timor.

To achieve this aim, the cell developed a blueprint for the neutralisation of the militia groups. The blueprint called for a phased program involving the following steps:

- *Information.* INTERFET believed that the militiamen were operating under an incorrect understanding of the

---

<sup>44</sup> Faulkner and Duff, *op. cit.*, p. 29.

political situation. INTERFET sources indicated that the militia groups believed that Indonesia had *not* ratified the popular consultation result and that the Western Regencies would be annexed to Indonesia. The Information Operations Cell set out to deliver a correct appraisal of the political situation.

- *Reassessment.* The information campaign involved forcing the militia groups to reassess their motivation for continued hostilities and their chances of success.
- *Dislocation.* The aim of the dislocation phase was to dislocate the militia leaders from external support and separate them from the rank-and-file militiamen in order to render them ineffective.
- *Reconciliation.* INTERFET planned to change the militia groups' perception of their future by emphasising that reconciliation was the way forward.

The most effective way to transmit these messages to the militia groups was through leaflet drops by aircraft along the border (see Figure 6). These drops required detailed and careful planning to ensure that the targeted areas were those that militiamen would visit.



**Figure 6: Leaflet airdrop along the border**

While it is difficult to determine the effect of the information campaign on the militiamen, there were reports from units that members of the militia had turned themselves in with leaflets in their possession. Independent sources indicated that leaflets had been seen up to 40 kilometres inside West Timor. As it was not possible to drop the leaflets in these areas, it can only be assumed that individuals carried them as they moved around. This type of report re-emphasises the suggestion that the local population valued any information it could obtain and that it would be retained in an individual's possession if at all possible. Figure 7 is an example of a leaflet that was distributed in East Timor.

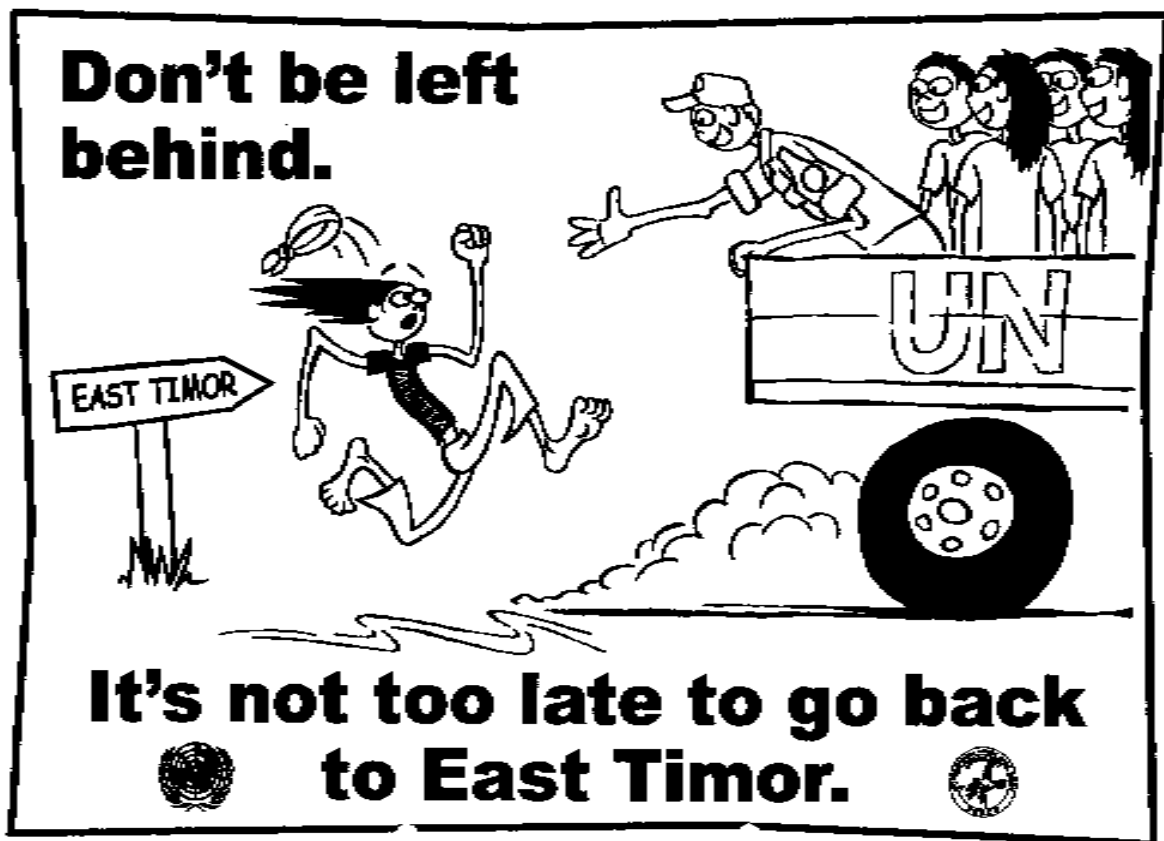

Figure 7: Leaflet encouraging people to return to East Timor

## **Loudspeaker Operations**

At various times during Operation *Stabilise*, members of the Psyops Platoon conducted loudspeaker operations to broadcast both psyops messages and public information to target audiences. Loudspeaker operations are limited by the nature of the equipment and, as such, require detailed planning to ensure that the message reaches its target audience.

The loudspeaker operations were conducted as both pre-planned and reactive tasks. Pre-planned operations included the broadcasting of messages along the border to advise internally displaced persons that it was safe to return home and that humanitarian assistance was available. Reactive operations were used when incidents of potential crowd violence arose in Dili and loudspeaker teams were deployed to broadcast messages to the crowd in order to defuse the situation. When such incidents could be identified in their formative stages, loudspeaker teams were included in contingency planning, messages recorded and teams pre-positioned to support INTERFET troops.

## **EFFECTIVENESS OF THE INFORMATION CAMPAIGN**

### **Measures of Effectiveness**

One of the inherent difficulties of any information campaign lies in measuring its effectiveness. This is a consequence of the fact that the tangible results are spread over the broad and disparate elements of a population and many take time to appear in recognisable form. Changes to attitudes and perceptions, in particular, may take a long period of time to manifest themselves. The SFOR operation in Bosnia utilised a range of methods to assess the effectiveness of its



information campaign. These methods included bilateral meetings, opinion polls, surveys, analysis of a range of media sources, human intelligence and the assessments of psyops teams, including patrols. Reading the attitudes of the local populace provided the only insight into what messages had been received and whether these were the intended ones. The ultimate measure of effectiveness for the SFOR forces lay in the careful observation of specific targets and the noting of any behavioural changes.

Measurement of the success or failure of the INTERFET information campaign proved similarly problematic. One of the major difficulties involved timely and accurate feedback on the products and their effect on the target audience. Units and formations were requested to provide data regarding the effects of information even if these appeared to be insignificant at the time. The aim was to try to build a complete picture of situational change, including such intangibles as attitudinal change, resulting from the information campaign.

Much of the information received was anecdotal in nature. It was difficult to determine the effect of items such as the air-dropped leaflets on the Timorese populace. A more tangible indicator lay in reports that linked information products directly to the concrete actions of the target audience. One such report stated that a militia member had handed himself in with a leaflet in his possession. The leaflet was designed to encourage militia members to consider ceasing hostilities for the sake of their families. The report raised the possibility that this leaflet was handed to the militia member by his son and, as a direct result, the militiaman surrendered.



The Information Operations Cell treated this report with caution, but as potentially very positive feedback, and considered the possibility that the report presented tangible evidence that its leaflet campaign was producing a change of attitude among the militia groups. In reality, however, it was recognised that this isolated report was inadequate to be of any concrete value. The cell could not rely on solitary incidents such as this to provide a measure of effectiveness.

An attempt was also made to quantify the effectiveness of information operations in relation to the return of internally displaced persons from West Timor. The particular target was the mass-information campaign being conducted by UNHCR with some INTERFET support. Each day the number of people returning to East Timor was recorded and matched against significant events in the information campaign or external events. The results were graphed in an attempt to identify trends or changes and match them to events.

While the value of this data in accurately determining the effectiveness of the information campaign is questionable, it did provide evidence of trends such as the impact of religious periods on the numbers of people returning to East Timor. Given that East Timor is a predominantly Roman Catholic country, the figures were expected to indicate reduced numbers of internally displaced persons moving on Sundays, the primary day of worship. This was indeed the case. Monday also proved to be a day of lower rates of movement since internally displaced persons who wished to return were required to register on the Sunday before and fewer did, given their involvement in Sunday worship. Similarly, the figures indicated a decline over the holy periods of Christmas and New Year since the internally displaced persons focused on religious activities. New Year in the year 2000 was particularly significant to

the East Timorese, since it represented the jubilee of the birth of Christ, 2000 years ago.

The Information Operations Cell could also monitor the impact of significant announcements on the return figures, allowing the cell to make an assessment of that impact. One such announcement was the statement by a militia leader that all militia groups were to disband. While this particular announcement was not significant, it is an example of the large number of announcements monitored by the cell.

### **Key Lessons Learnt**

The creation and implementation of a successful information campaign has pushed the Australian Defence Force into largely uncharted waters, both in the case of Operation *Stabilise* and its predecessors, including Operation *Bel Isi*. Raising the information operations profile throughout the Australian Defence Force is vital, since there is little recognition of what can achieve. This lack of recognition may be a function of the perceived difficulty in measuring the effectiveness of information operations. The character of information operations dictates reliance on observation and deduction using the analysis of reports. Commanders must be convinced that the dedication of scarce resources to information collection represents an investment that is worthwhile.

One of the problems that has beset information campaign planners internationally has been the lack of doctrine to underpin intuition and commonsense with sound principles, tactics, techniques and procedures. The US Army, US Marine Corps and Canadian Armed Forces have all developed information operations doctrine over recent years. The United States has also produced joint information

operations doctrine that will underpin planning in multinational theatres. At the time of the INTERFET mission, the Australian Defence Force found itself in a doctrinal void, with only unendorsed doctrine to guide the employment of information operations.

The skills of information experts must be maximised and developed, if their extraordinary gains are not to be lost to the Australian Defence Force. Attendance at the appropriate training courses, both within Australia and internationally, is crucial to provide a vehicle for the introduction and the advanced study of information operations. Commanders and planners must be persuaded to accept of the important role that information plays in any military mission of this type.

As a means of communication with a broad international audience, the Internet was very much under-exploited by INTERFET in the early stages of the operation. An INTERFET Internet web page would have been the ideal location to post information of an unclassified nature—for example, the *New East Timor* and monthly situation reports—so as to communicate the INTERFET message to the wider media and international community. The United Nations agencies and NGOs did precisely that, utilising the Internet to provide information to a global audience on a broad range of issues.

While East Timor lacked the communications infrastructure to exploit the Internet on a domestic basis, the campaign to convey the INTERFET message, particularly to international media agencies, could have been waged in the ether. On the other side of the world, US forces in Operation *Allied Force* were quickly confronted with the power of the Internet: ‘To this day, NATO has no idea how many Internet forums were being used by the Serbs to support their cause’.<sup>45</sup>

---

<sup>45</sup> Troop Sergeant M. Philen, cited in Pounder, *op. cit.*, p. 74.

## CONCLUSION

Operation *Stabilise* represented a significant opportunity for the Australian Defence Force to explore the potential of information and exploit its many capabilities. According to the Canadian Armed Forces publication, *Land Force Information Operations*,

IO [is] designed to enhance or magnify the effect of friendly combat power and diminish that of the enemy . . . IO allows us to operate in expanded areas of operation . . . IO involves more than a force attacking an adversary's information flow while protecting its own. It requires awareness of, and sensitivity to, non-military information sources . . . which can influence military operations, leadership perceptions and the flow of information through information systems.<sup>46</sup>

Given the vast suite of dimensions that describe information operations, it is little wonder that information campaigns in recent military operations, both Australian and international, have been characterised by the upward sweep of a broad learning curve. They have also been marked by maximum adaptability to conditions within their respective battlespaces. What worked for SFOR in Bosnia would not have met the starkly differing conditions during Operation *Allied Force*. What worked for the Australians during Operation *Bel Isi* was not always appropriate for the circumstances of Operation *Stabilise*. Flexibility and adaptation have been the hallmarks of these information campaigns, born of the recognition of the disparate needs of each battlespace.

The other factor that has dictated such a significant learning curve has been the recognition that the battlespace itself—the traditional area of operations—has now changed. Increasingly there is a recognition that ‘the [area of

---

<sup>46</sup> *Land Force Information Operations, op. cit.*, pp. 4–6.

operations] now goes beyond the traditional physical dimensions of time, width, depth and height'.<sup>47</sup> No longer is the area of operations confined to that piece of terrain in dispute or even to other areas of the target country that may influence the outcome of a conflict.

The battlespace is now expanded beyond all former frontiers to what has been termed a 'fifth dimension'.<sup>48</sup> Information operations occupy that fifth dimension. The information battlespace includes the airways, the electromagnetic domain and the hearts and minds of not only combatants, not only local communities, but entire nations. Beyond that, the information battlespace expands to include the perceptions of the international media and their global audience. The information operations planner who seeks to make a contribution to the design of a military campaign is now confronted by the complexity of the new cyber-battlespace.

Such was the dilemma that confronted information operations planners in the early days of Operation *Stabilise*. The conduct of information operations throughout the entire operation was a significant learning experience for the Australian Defence Force. Like their overseas counterparts, Australian information operations planners found that rudimentary knowledge of information use within the Australian Defence Force required considerable initiative and a tolerance for trial and error.

During Operation *Stabilise*, information operations planners depended to a great extent on their commander's guidance. The Information Operations Cell developed the programs, the processes and the synchronisation matrix to reflect this guidance. The cell gradually adapted to local conditions, and

---

<sup>47</sup> *Ibid.*, p. 5.

<sup>48</sup> Fogleman, *op. cit.*, p. 1.

the conduct of the information campaign proceeded smoothly. The broad aims of the INTERFET campaign—including the general support of the East Timorese population, the gradual rehabilitation of internally displaced persons and the disarming of the militia groups—were achieved. Above all, the campaign aimed to assist INTERFET to nurture a peace and stability that would create a climate for reconstruction, and the smooth transition to UNTAET.

Not surprisingly, the INTERFET information campaign went unnoticed by a great majority of the forces deployed. This ‘anonymity’ speaks highly of the means by which a peacekeeping force can effectively use a subtle underlying campaign to change perceptions and attitudes. Rather than rely on force or threats, the information campaign relied on psychological techniques to shape the local environment. INTERFET conducted the campaign within the framework of the commander’s guidance, based on identifiable and achievable aims and objectives.

The success of the information campaign itself has been measured by perceptions and personal assessments, decrying the lack of any tangible yardsticks for the measurement of effectiveness. Nevertheless, the information campaign succeeded in assisting the INTERFET forces to create an enduring bond between the people of East Timor, the Australian Defence Force and the Australian people. The INTERFET information campaign was not a perfect campaign, and could not have been, given the circumstances of its birth. The end result is, however, its greatest testament to success. As was said of Operation *Allied Force*, ‘Yet their efforts still contributed to NATO’s ultimate victory; after all it was Milosevic who capitulated, not the alliance’.<sup>49</sup>

---

<sup>49</sup> Pounder, *op. cit.*, p. 76.

There is little doubt that the information campaign contributed significantly to the success of Operation *Stabilise*. Perhaps the campaign's most tangible and enduring legacy lies in the friendship and goodwill that now characterise Australia's relationship with the new nation of East Timor. The legacy of information operations in East Timor is that it has created a firm foundation for the future use of such operations within the Australian Defence Force.

**LAND WARFARE STUDIES CENTRE PUBLICATIONS****Working Papers**

- 101 Evans, Michael, *The Role of the Australian Army in a Maritime Concept of Strategy*, September 1998.
- 102 Dunn, Martin, *Redefining Strategic Strike: The Strike Role and the Australian Army into the 21st Century*, April 1999.
- 103 Evans, Michael, *Conventional Deterrence in the Australian Strategic Context*, May 1999.
- 104 de Somer, Lieutenant Colonel Greg, *The Implications of the United States Army's Army-After-Next Concepts for the Australian Army*, June 1999.
- 105 Ryan, Alan, *The Way Ahead? Alternative Approaches to Integrating the Reserves in 'Total Force' Planning*, July 1999.
- 106 de Somer, Lieutenant Colonel Greg, *The Capacity of the Australian Army to Conduct and Sustain Land Force Operations*, August 1999, reprinted October 1999.
- 107 de Somer, Lieutenant Colonel Greg, *Professional Mastery: The Human Dimension of Warfighting Capability for the Army-After-Next*, October 1999.
- 108 Zhou, Lieutenant Colonel Bo, *South Asia: The Prospect of Nuclear Disarmament After the 1998 Nuclear Tests in India and Pakistan*, November 1999.
- 109 Ryan, Michael and Frater, Michael, *A Tactical Communications System for Future Land Warfare*, March 2000.
- 110 Evans, Michael, *From Legend to Learning: Gallipoli and the Military Revolution of World War I*, April 2000.
- 111 Wing, Ian, *Refocusing Concepts of Security: The Convergence of Military and Non-military Tasks*, November 2000.
- 112 Ryan, Michael and Frater, Michael, *The Utility of a Tactical Airborne Communications Subsystem in Support of Future Land Warfare*, April 2001.
- 113 Evans, Michael, *From Deakin to Dibb: The Army and the Making of Australian Strategy in the 20th Century*, June 2001.
- 114 Ryan, Alan, *Thinking Across Time: Concurrent Historical Analysis on Military Operations*, July 2001.
- 115 Evans, Michael, *Australia and the Revolution in Military Affairs*, August 2001.



- 116 Frater, Michael and Ryan, Michael, *Communications Electronic Warfare and the Digitised Battlefield*, October 2001.
- 117 Parkin, Russell, *A Capability of First Resort: Amphibious Operations and the Australian Defence Policy, 1901–2001*, May 2002.
- 118 Blaxland, John, *Information-era Manoeuvre: The Australian-led Mission to East Timor*, June 2002.
- 119 Connery, David, GBAeD 2030: A Concept for Ground-based Aerospace Defence in the Army-After-Next, July 2002.

### Study Papers

- 301 Evans, Michael, *Forward from the Past: The Development of Australian Army Doctrine, 1972–Present*, August 1999.
- 302 Ryan, Alan, *From Desert Storm to East Timor: Australia, the Asia-Pacific and the ‘New Age’ Coalition Operations*, January 2000.
- 303 Evans, Michael, *Developing Australia’s Maritime Concept of Strategy: Lessons from the Ambon Disaster of 1942*, April 2000.
- 304 Ryan, Alan, ‘Primary Responsibilities and Primary Risks’: *Australian Defence Force Participation in the International Force East Timor*, November 2000.

### Books

Wahlert, Lieutenant Colonel G. (ed.), *Australian Army Amphibious Operations in the South-West Pacific: 1942–45*, Army Doctrine Centre, Department of Defence, Puckapunyal, Vic., 1995.

Dennis, Peter and Grey, Jeffrey (eds), *From Past to Future: The Australian Experience of Land/Air Operations*, University of New South Wales, Australian Defence Force Academy, Canberra, 1995.

Horner, David (ed.), *Armies and Nation Building: Past Experience—Future Prospects*, Australian National University, Canberra, 1995.

Dennis, Peter and Grey, Jeffrey (eds), *Serving Vital Interests: Australia’s Strategic Planning in Peace and War*, University of New South Wales, Australian Defence Force Academy, Canberra, 1996.

Malik, Mohan (ed.), *The Future Battlefield*, Deakin University, Geelong, Vic., 1997.

Smith, Hugh (ed.), *Preparing Future Leaders: Officer Education and Training for the Twenty-first Century*, University of New South Wales, Australian Defence Force Academy, Canberra, 1998.

Evans, Michael (ed.), *Changing the Army: The Roles of Doctrine, Development and Training*, Land Warfare Studies Centre, Duntroon, ACT, 2000.

Evans, Michael and Ryan, Alan (eds), *The Human Face of Warfare: Killing, Fear and Chaos in Battle*, Allen & Unwin, Sydney, 2000.

